

# VariStroke-I

## Electro-hydraulic Actuator

### Applications

The VariStroke-I is a linear electro-hydraulic actuator that is designed to provide the linear actuation force to operate steam turbine control valves or valve racks. This integrated actuator is intended for use on mechanical-drive or generator-drive steam turbines, and uses a low-pressure hydraulic oil source (typically turbine lube oil) to provide its output shaft force.

The VariStroke-I's superb accuracy and resolution make it ideal for steam turbine valve control and related turbine speed and load control. The VariStroke-I electronics module accepts one or two (redundant) 4–20 mA position demand signals to position steam control valves. Precise and stable steam valve control directly relates to improved steam turbine speed and load control and reduced system mechanical wear. The actuator's fast slew rates (ranging from 200 to 500 mm/s) allows applied generator or compressor drive turbines to quickly respond to loss-of-load or emergency shutdown events.

The VariStroke-I actuator's robust design (corrosion resistant materials, single moving rotary valve, 50 lb chip shear force, and self-cleaning port design) make it ideal for challenging applications where dirty or contaminated oil may be present.

This actuator can be purchased in the configuration which best meets the specific application's requirements (Integrated, Remote Servo, or Servo Only models are available). Refer to Figures 1 to 3 below.

The VariStroke-I's redundant features make it ideal for critical steam turbine applications, where turbine up-time and availability are essential. This linear actuator can be configured to accept simplex or dual-redundant position demand inputs, then select the correct input to follow. This linear actuator's dual-redundant 4–20 mA demand inputs and dual-redundant MLDT (magnetostrictive linear displacement transducer) shaft position sensors allow it to continue to operate even with demand input or feedback sensor failures, ensuring extend run-times between forced outages.

In turbine retrofit applications, the VariStroke-I can be used to directly replace the existing servo system. This saves costly repairs to existing and aging servos, eliminates the difficulty of obtaining spare parts for obsolete equipment, and reduces calibration time and difficulty.



- Dirt-tolerant design
  - Two moving parts
  - 50 lb chip shear force
  - Self-cleaning valve design
- Variable / configurable shaft stroke lengths
- Fast slew rates/times
  - Application dependent
  - Slew rates range from 200 to 500 mm/s (8 to 20 inches/second)
- Precise position control
- Side-load tolerant
  - Shaft bearings
  - Triple seal technology
- Integrated driver
  - Two 4–20 mA demand inputs
  - Included valve flow linearization table
- Redundant MLDT position sensors
- Certified for Hazardous Locations

## Description

---

The VariStroke-I is a linear electro-hydraulic actuator that utilizes a double-acting or single-acting power cylinder (part number dependent) with integrated electronic driver module, servo valve, and MLDT-based position feedback sensors to precisely control steam turbine valves. The actuator's driver module accepts one or two (redundant) 4–20 mA demand setpoints and compares these setpoints to the sensed actuator shaft position to accurately control output shaft position.

The actuator's output shaft position is controlled by a digital controller with an internal rotary servo valve that ports supply oil to and from its power cylinder piston. This actuator's special digital controller architecture allows it to perform very stable position control during normal conditions, and also respond in milliseconds to desired valve step changes during system or plant transients. As a means of protecting the turbine, an internal valve-return spring forces the actuator to a failsafe position to safely close turbine control valves upon any internal unit failure (electrical input power failure, position sensor failure, processor failure, etc.).

The VariStroke-I actuator is a product family with different models available for purchase depending on the force, stroke, and redundancy required. This actuator is available with standard bore diameters, standard stroke ranges, and with single-acting (spring return) or double-acting (pressure return) operation. The VariStroke's unique "variable stroke" capability also allows users to customize/set the actuator's exact stroke length in the field to meet their required application.

The VariStroke-I is factory and/or field configurable via a computer-based service tool. The actuator's PCI Service Tool uses a simple user-friendly format to allow users to easily configure, calibrate, and adjust all internal functions and response settings. The VariStroke-I also includes a 4–20 mA output channel to indicate output shaft (control valve) position, and unit alarm and shutdown relay outputs for use as unit health and status indications.

The total installed cost for this fully integrated actuator is low because it has been completely assembled and tested at the factory. This greatly reduces OEM and end-user fabrication time, testing time, and site assembly time.

## Features

---

**Dirt Tolerance**—The VariStroke-I actuator is specifically designed for steam turbine applications where turbine lube oil is also used to power the hydraulic turbine control valve actuator(s). Steam turbine applications can be extremely challenging for hydraulic control valve actuators as dirt, metal shavings, water, and other contaminants (babbitt, ammonia, etc.) are common in such oil systems. Also due to the high temperatures at which steam turbines operate, turbine oil breakdown is common, resulting in the creation of a sludge-type substance and the varnishing of internal system components. However, the VariStroke-I actuator is designed to operate reliably within such challenging applications. Its corrosion-resistant materials, single moving rotary valve, 50 lb of chip shear force, and self-cleaning port design allow it to operate in such applications without experiencing undesirable sticking or dragging actions.

**Valve Rack Linearization**—Since flow-through single and staged inlet steam valves tend to be non-linear throughout their flow range, turbine controls are typically de-tuned to compensate for instability or sluggish control points throughout this range. As a way of allowing turbine control optimization, the VariStroke-I includes an 11-point linearization table to allow turbine OEMs or users to compensate for poor valve linearization by digitally linearizing the control-to-valve flow relationship.

**Side Load Capability**—A common problem with turbine actuators is oil leaking from their output shaft due to connection to valve rack linkages which have an arc-type of motion. This motion results in side loading of the actuator shaft, and after long periods may result in shaft-seal wear and resultant oil leakage. Designed for a continuous side load of up to 10% of actuator output, the VariStroke-I actuator incorporates a high-force precision bearing and special seal technology on its output shaft to solve this typical application problem.

**Soft Stop Capability**—Turbine valve seat life is always a concern among turbine OEMs and owners. To assist with extending the life of turbine control valves (or valve racks) and their valve seats, the VariStroke-I actuator includes a "Soft Stop" feature which allows users to optionally configure a point above the valve seat (mechanical stop) to slow the valve's rate of travel, thus softening how hard the valve rack strikes its valve seat (minimum mechanical stop) and lengthening the life of both the valve and the valve seat.

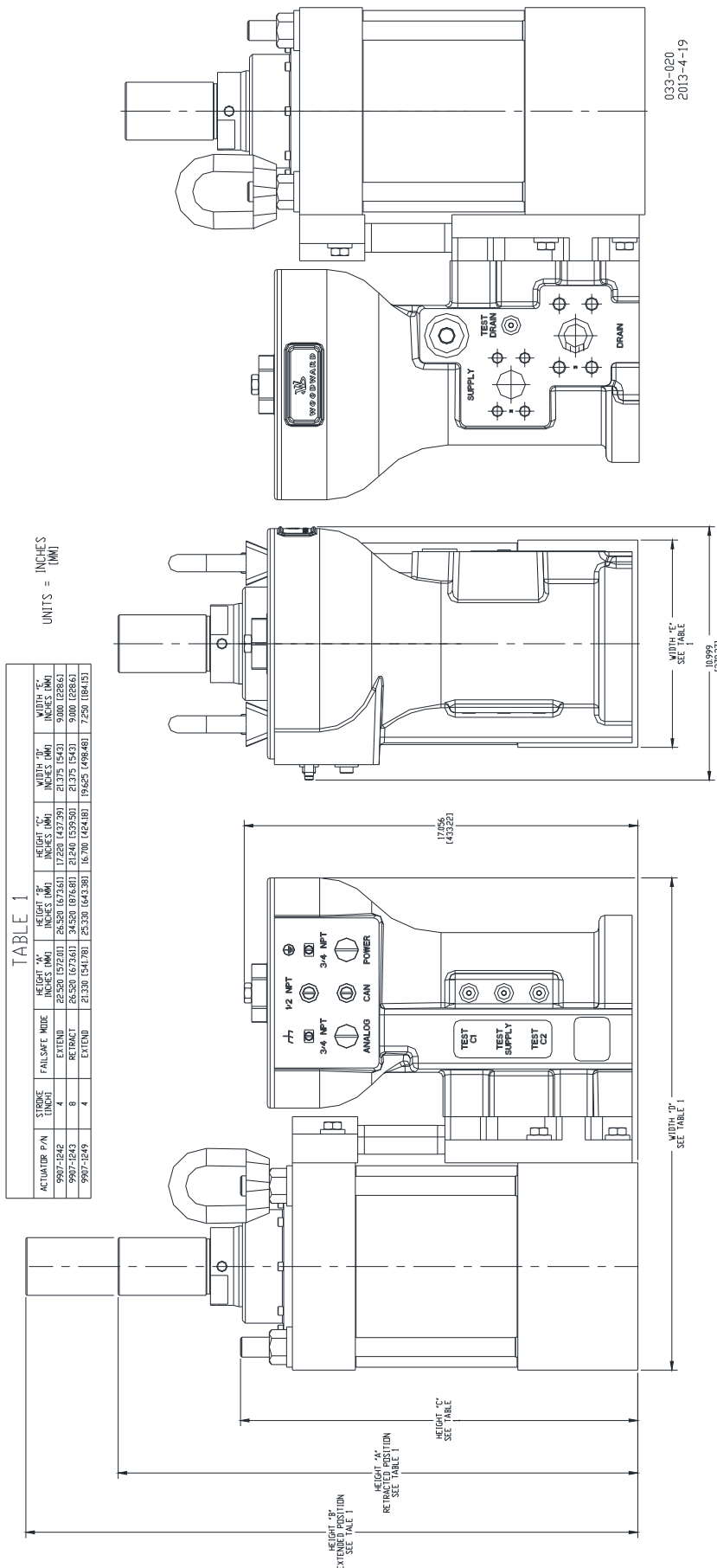

Figure 1. VariStroke-I Outline Drawing (102–203 mm / 4–8 inch model only)

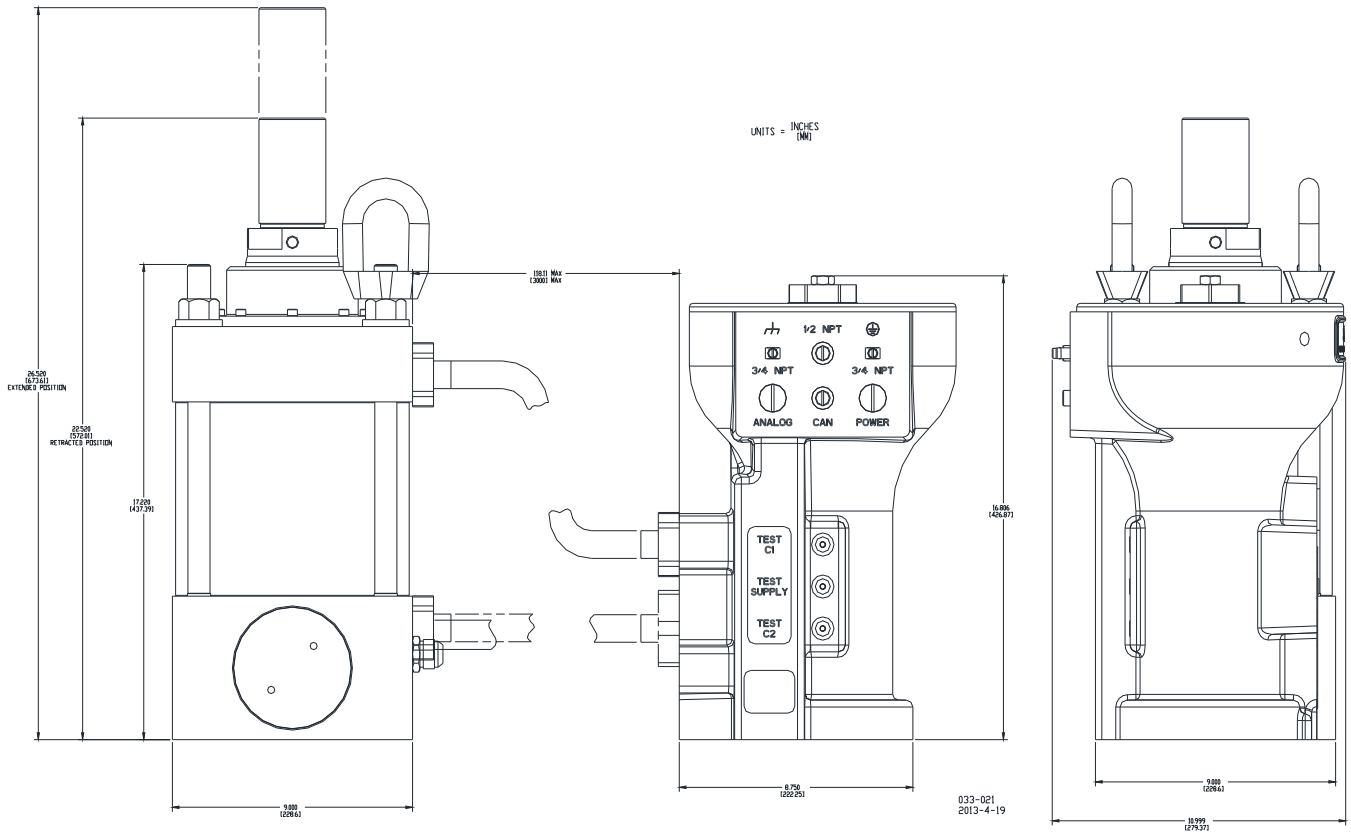

Figure 2. Remote Servo Kit Outline Drawing

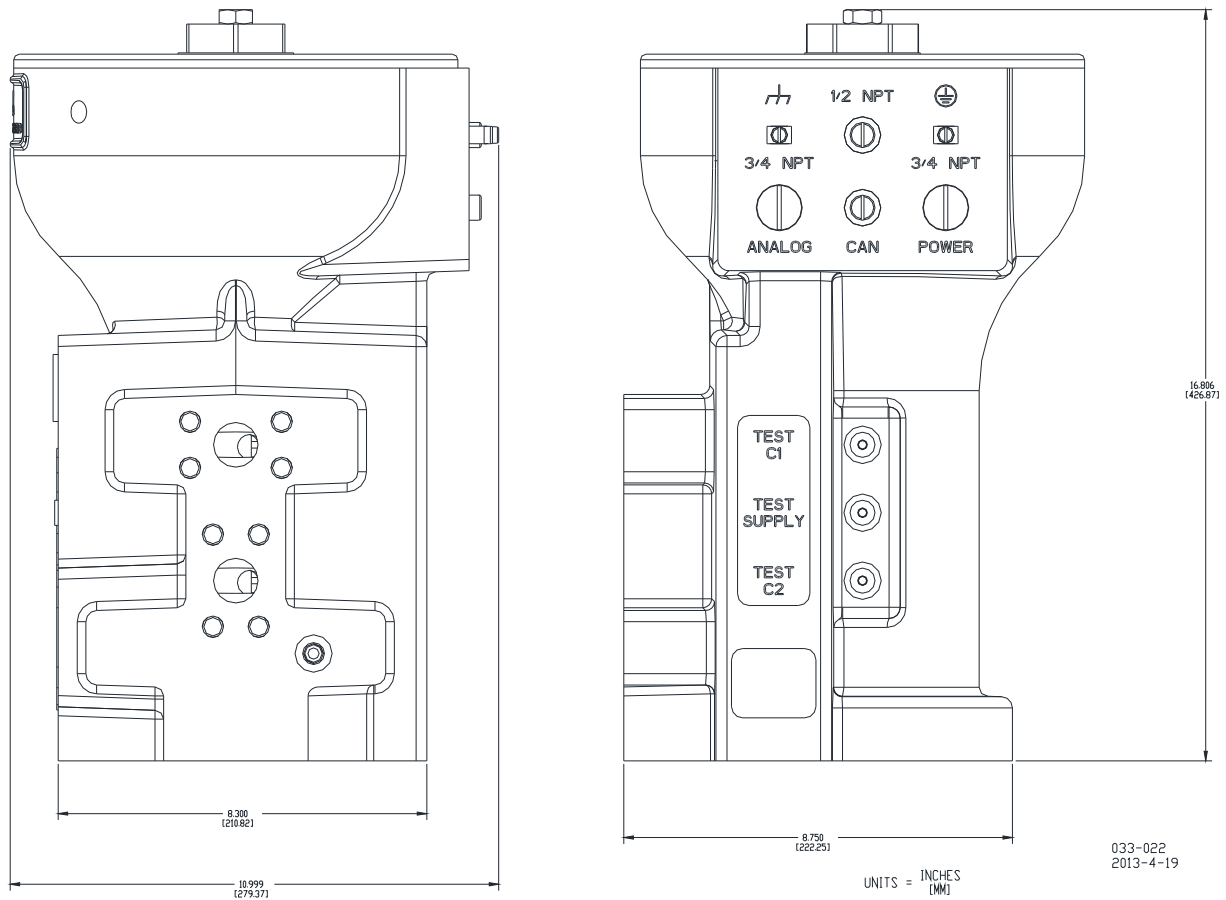

Figure 3. Servo Only Outline Drawing

## Specifications

### Performance

Position Accuracy:	±1% of full range
Position Repeatability:	±0.5% of full range
Temperature Drift:	0.04%/°C
Failsafe Operation:	Internal return spring on servo valve
Open Slew Rate:	> 200 mm per second (8 inches/second)
Close/Trip Slew Rate:	203 mm per second (9 inches/second)
Configuration:	Computer based Service Tool (RS-232 communications port)

Linearization table allows valve rack flow linearization.

### Physical

Available Model Stroke Range:	51–102, 76–153, 102–203 mm / 2–4, 3–6, 4–8 inches
Max Stall Force:	Determined by model number (cylinder bore size & direction dependent) Retract direction = 1700—14 000 kgf @ 35 bar / 3800—31 000 lbf @ 500 psi Extend direction = 2900—17 800 kgf @ 35 bar / 6300—39 200 lbf @ 500 psi
Cylinder Dimensions:	Determined by model number; available bore sizes (102, 153, 203 mm / 4, 6, 8 inches)
Cylinder Types:	Double-acting (future single-acting models planned)
Failsafe Direction:	Extend or Retract (determined by model number)
Actuator Dimensions:	Determined by configuration
Weight:	Determined by model number
Mounting:	Any attitude (bolt patterns & sizes are determined by model number)

### Environmental

Operating Temperature Range:	–40 to +85 °C (–40 to +185 °F)
Operating Oil Temperature Range:	+15 to +70 °C (+59 to +158 °F)
Shock:	US MIL-STD-810C method 516.2, procedure 1 (10 G peak, 11 ms duration, sawtooth waveform)
Vibration:	US MIL-STD-810F, M514.5A, Cat. 4 (0.015 G <sup>2</sup> /Hz, 10–500 Hz, 1.04 Grms)
Ingress Protection:	IP66 per EN 60529 <b>PENDING</b>

### Electrical

Input Supply:	18–32 Vdc @ 3.0 A steady state, 10 A peak (100 ms)
Analog Input Signals:	Isolated 4–20 mA (200 Ω input impedance)
Analog Output Signal:	4–20 mA – maximum external load: 300 Ω
Discrete Inputs:	Optically Isolated (requires 24 Vdc wetting voltage)
Discrete Outputs Rating:	1 A @ 30 Vdc
Service Tool Port:	RS-232 communications

### Hydraulic

Supply Pressure Range:	5.5 to 35 bar (80 to 500 psi)
Fluid Types:	Mineral or synthetic or Fyrquel EHC-based oils may be used
Recommended Oil Cleanliness:	24 to 40 μm nominal, β <sub>75</sub> (ISO 4406 code 20/18/16 Class) max
Recommended Viscosity:	20 to 100 centistokes
Fluid Ports:	SAE J518 Code 61
Steady State Oil Consumption Max:	9.5 L/min @ 35 bar (2.5 US gal/min @ 500 psig)
Max Flow Rate:	321 L/min @ 7 bar / 85 US gal/min @ 100 psig 681 L/min @ 35 bar / 180 US gal/min @ 500 psig
Return/Drain Pressure:	Maximum: 2 bar (29 psi)

### **PENDING** Regulatory Compliance

European Compliance for CE Marking:

EMC Directive:	2004/108/EC
ATEX Directive:	94/9/EC Zone 2, Category 3, Group II G Ex nA II T3; and LCIE 08 ATEX 6123 Zone 1, Category 2, Group II G Ex d IIB T3 and LCIE 08 ATEX 6124 Zone 2, Category 3, Group II G Ex nA IIC T3

Other European/International Compliance:

GOST R: Certified for use in explosive atmospheres within the Russian Federation per GOST R certificate POCC US.ΓB04.B01595 as 1ExdIIBT3X and 2ExnAIIIT3X

Machinery Directive: Compliant as a component with 98/37/EC

Pressure Equipment Directive: Compliant as “SEP” per Article 3.3 to 97/23/EC

North American Compliance:

cUL: Certified for Class I, Division 1, Groups C and D and Class I, Division 2, Groups A, B, C, and D, T3 at 93 °C Ambient for use in Canada and the United States.

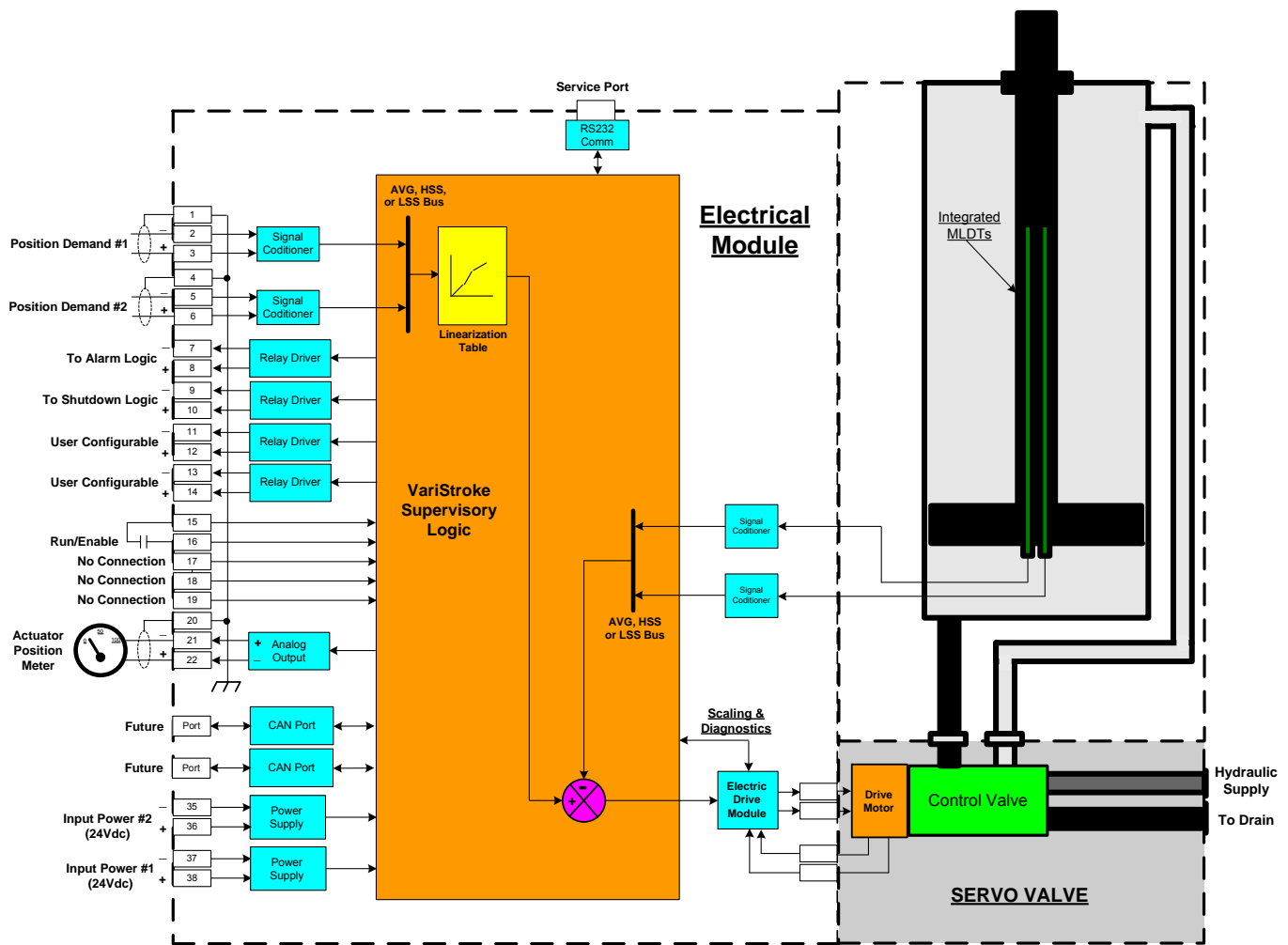

Figure 4. VariStroke-I Interface Schematic



PO Box 1519, Fort Collins CO, USA 80522-1519  
 1000 East Drake Road, Fort Collins CO 80525  
 Tel.: +1 (970) 482-5811 ♦ Fax: +1 (970) 498-3058  
[www.woodward.com](http://www.woodward.com)

**Distributors & Service**

Woodward has an international network of distributors and service facilities. For your nearest representative, call the Fort Collins plant or see the Worldwide Directory on our website.

This document is distributed for informational purposes only. It is not to be construed as creating or becoming part of any Woodward contractual or warranty obligation unless expressly stated in a written sales contract.

Copyright © Woodward 2011–2013, All Rights Reserved

For more information contact: